

Configuration sheet

CASHIER SAFETY COMMUNICATION Cashiers can communicate internally

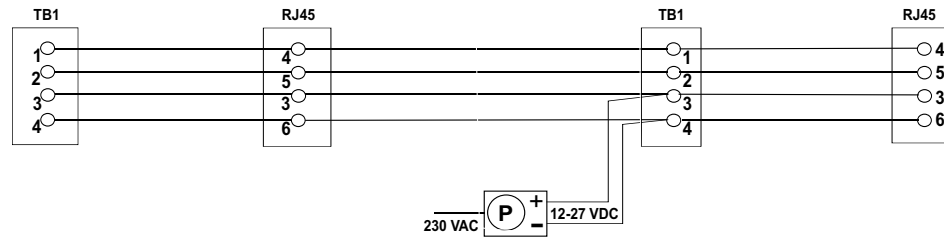
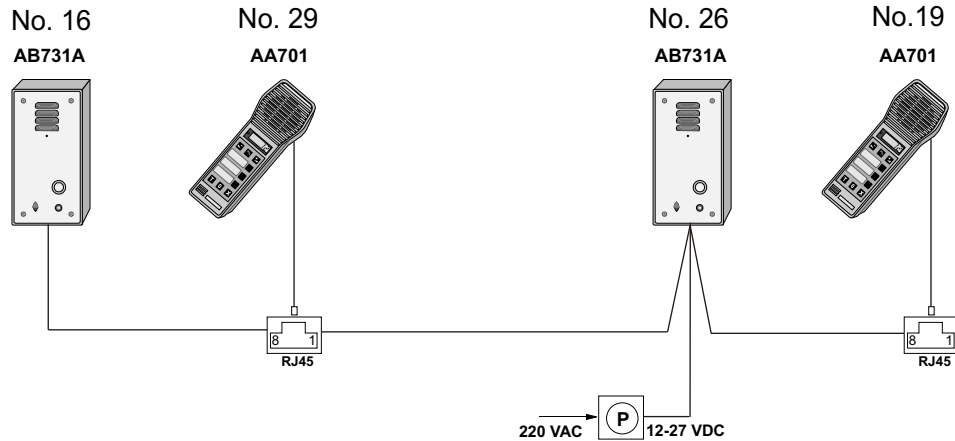

P: Power supply

A petrol station has 2 cashier positions.
Each cashier is sitting inside the station and is separated from the outside by a glass window.
The customer at the outside can call the cashier by pressing the call button in the AB731A station.
The cashier can also call the outside by pressing one of the call buttons in the AB707 station.
The two cashiers can call each other by pressing one of the other call buttons on the AB707 station.

Cashier station no. 29.
The lower call button is dialling the other cashier at call no.19
The middle call button is dialling the local customer station at call no.16

Cashier station no. 19.
The lower call button is dialling the other cashier at call no.29
The middle call button is dialling the local customer station at call no.26

Pro700

15 911 020

Pro700 products are developed and marketed by ZENITEL NORWAY ASA.
The company's Quality Assurance System is certified to meet the requirements in NS-EN ISO 9001:2000. ZENITEL NORWAY ASA reserves the right to modify designs and alter specifications without prior notice, in pursuance of a policy of continuous improvement.