

Configuration sheet

POLICE STATION Door - Guard - Cell Communication

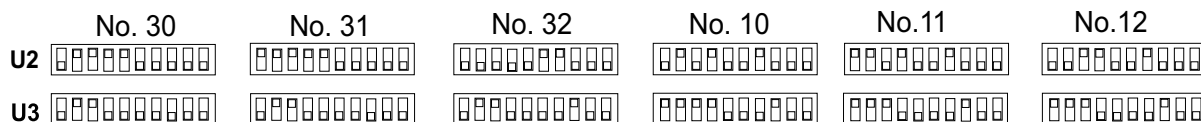
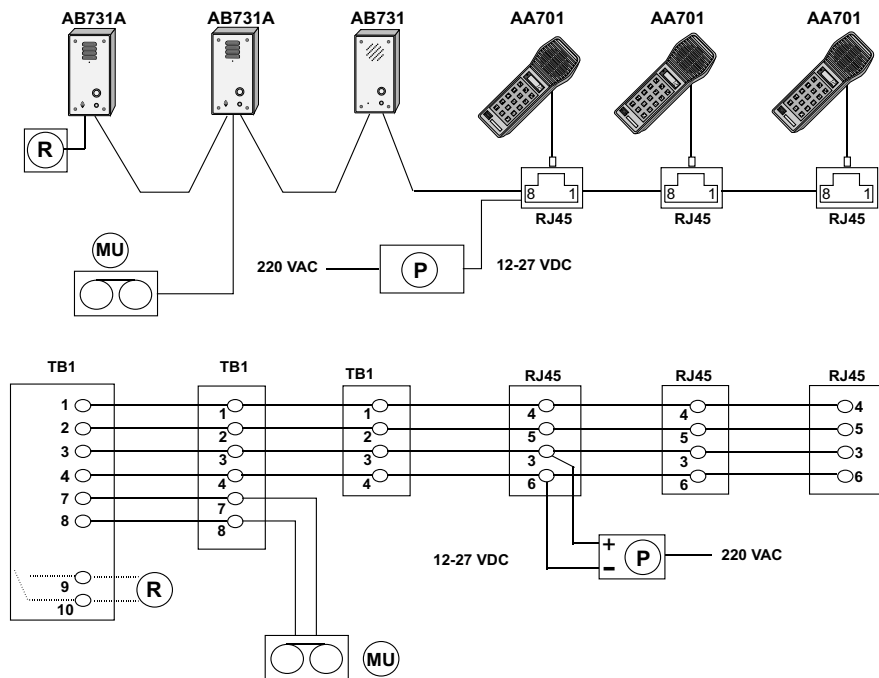

CALL ANNUNCIATION SYSTEM (CAS) WITH THREE GUARDS

One AB731 is located inside the cell of a police station.
 Two AB731A are located outside two entrance doors.
 The internal relay in station no.30 is used to open the door at that station.
 The internal relay is operated from station no.10, 11 or 12 by pressing the "5" button when connected in conversation with no.30.
 When waiting in the call queue, stations no.30 and 31 are connected to a music, or message source.
 Station no.32 will receive a ringing tone when waiting in the queue.

R:Door lock. Operated via the potential free contact inside the station
 P:Power supply. Should be located as close to the centre of the installation as possible.
 MU:Program source.

All stations no.30, 31 and 32 can make a call to the guards by pressing the call button.
 The call queue will be indicated in the display of stations no.10, 11 and 12.
 The calls are accepted one by one by pressing the "0" button in one of the stations 10,11 or 12.
 Station no.10, 11 and 12 can also dial the call number to all stations.

Pro700

15 911 007

Pro700 products are developed and marketed by ZENITEL NORWAY ASA.
 The company's Quality Assurance System is certified to meet the requirements in NS-EN ISO 9001:2000. ZENITEL NORWAY ASA reserves the right to modify designs and alter specifications without prior notice, in pursuance of a policy of continuous improvement.