

Configuration sheet

SUPERMARKET

Cashiers can request assistance for prices, money, etc.

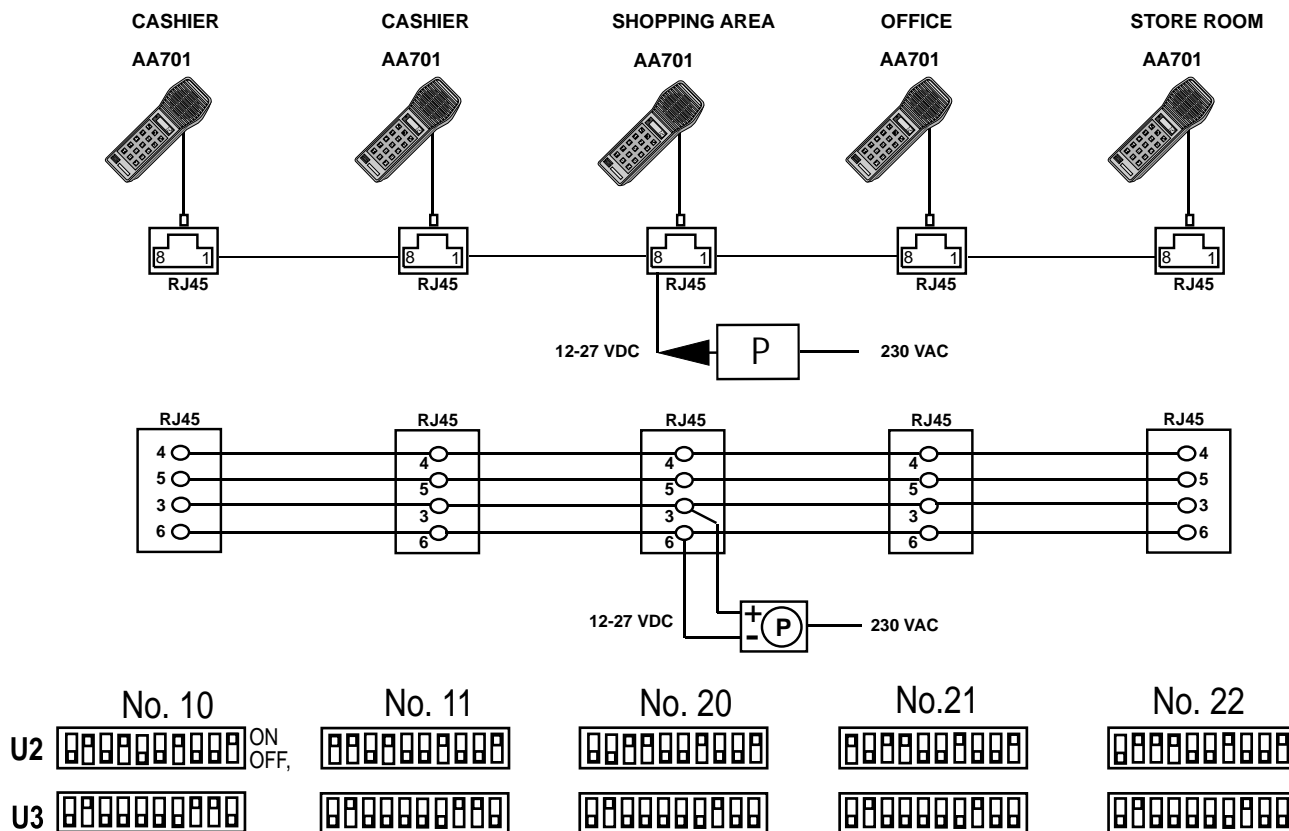

P: Power supply. Should be located as close to the centre of the installation as possible.

All stations are programmed as direct dialling 10 keys stations.

All stations are programmed with priority.

The cashier stations are programmed to direct dial no.20 - -28

Stations no. 20 - - 28 are programmed to direct dial the cashier stations, no. 10 - - 18.

An 'emergency' call can be made by pressing button 9.

The caller can speak as long as button 9 is pressed, and all stations will receive the message simultaneously.

The 'emergency call' will be cancelled automatically when button no.9 is released.

The 'emergency call' will automatically cancel an ongoing conversation, which has been established by pressing one of the buttons from 0 to 8 (direct dialling).

This example is only one of many possible configurations for a system in a supermarket.

Pro700

15 911 023

Pro700 is a brand name owned by ZENITEL NORWAY ASA.
The company's Quality Assurance System is certified to meet the requirements in
NS-EN ISO 9001:2000.
ZENITEL reserves the right to alter specifications and design without notice.